

MM300 Series



U s e r ' s M a n u a l



MODELS:

MM311U
MM301U
MM301A

Isolated Input, Dual Voltage, Variable Speed SCR
Drives for Brush Motors

Copyright © 2013 by
Minarik Drives

All rights reserved. No part of this manual may be reproduced or transmitted in any form without written permission from Minarik Drives. The information and technical data in this manual are subject to change without notice. Minarik Drives and its Divisions make no warranty of any kind with respect to this material, including, but not limited to, the implied warranties of its merchantability and fitness for a given purpose. Minarik Drives and its Divisions assume no responsibility for any errors that may appear in this manual and make no commitment to update or to keep current the information in this manual.

Printed in the United States of America.

Safety Warnings

This symbol  denotes an important safety tip or warning. Please read these sections carefully prior to performing any of the instructions contained in that section.

- Have a qualified electrical maintenance technician install, adjust and service this equipment. Follow the National Electrical Code and all other applicable electrical and safety codes, including the provisions of the Occupational Safety and Health Act (OSHA), when installing equipment.
- Reduce the chance of an electrical fire, shock, or explosion by proper grounding, over-current protection, thermal protection, and enclosure. Follow sound maintenance procedures.
- **It is possible for a drive to run at full speed as a result of a component failure.** Please ensure that a master switch has been placed in the AC line to stop the drive in an emergency.
- **This drive is isolated from earth ground.** Circuit potentials are at 115 VAC or 230 VAC above earth ground. Avoid direct contact with the printed circuit board or with circuit elements to prevent the risk of serious injury or fatality. Use a non-metallic screwdriver for adjusting the calibration trim pots.

Contents

Safety Warnings	i
Specifications	1
Dimensions	3
Installation	6
Wiring	6
Shielding Guidelines	7
Chassis Drives (MM301U, MM311U)	8
Mounting	8
Heatsinking	9
Line Fusing	9
Speed adjust potentiometer	10
Cage-clamp terminals	11
Connections	12
Motor	12
Power Input	14
Field Output	14
START/STOP pushbuttons	15
Tachometer feedback	15
Voltage or current follower	16
Slide switches	17
Enclosed Drives (MM301A)	19
Mounting	19
Heatsinking	20
Line Fusing	20
Connections	21
Motor	22

Operation	24
Before applying power (all models)	24
Chassis Drives (MM301U, MM311U)	24
Speed adjust potentiometer input with START/STOP pushbuttons	25
Diagnostic LEDs	26
Line starting and line stopping	27
Decelerating to minimum speed	27
Dynamic braking	28
Dynamic brake resistor value	28
Enclosed Drive Operating Modes (Manual / Auto)	30
Enclosed Drive Operation	31
Calibration	32
Drive Calibration Procedure	34
MINIMUM SPEED (MIN SPD)	35
MAXIMUM SPEED (MAX SPD)	35
CURRENT LIMIT	36
IR COMPENSATION (IR COMP)	37
ACCELERATION (ACCEL)	39
DECELERATION (DECEL)	39
TACH VOLTS	40
Application Notes	42
Multiple fixed speeds	42
Adjustable speeds using potentiometers in series	43
Independent adjustable speeds	44
Reversing	45
RUN/JOG switch	46
Reversing with a DIGI=LOK Controller, Model DLC600	47

IV

Troubleshooting	48
Unconditional Warranty	54

Illustrations

Fig.	Description	Page
1.	MM301U and MM311U Dimensions	3
2.	MM301A Dimensions	4
3.	MM300 Series Layout	5
4.	Speed Adjust Potentiometer	10
5.	Cage-Clamp Terminal	11
6.	MM301U and MM311U AC Line, Motor and Field Connections	13
7.	Signal Follower Connection	16
8.	Slide Switches	18
9.	MM301A Connections	23
10.	Current Limit and Power LEDs	26
11.	Run/Decelerate to Minimum Speed Switch	28
12.	Dynamic Brake Connection	29
13.	Calibration Trimpot Layout	33
14.	Typical CURRENT LIMIT, and IR COMP Settings for MM300 Series (actual settings may vary with each application)	38
15.	Multiple Fixed Speeds	42
16.	Adjustable Fixed Speeds Using Potentiometers in Series	43
17.	Independent Adjustable Speeds	44
18.	Reversing Circuit Connection	45
19.	RUN/JOG Switch Connection to Speed Adjust Potentiometer	46
20.	Reversing with a DLC600	47
21.	MM300 Series Block Diagram	52

Tables

Fig.	Description	Page
1.	Recommended Line Fuse Sizes	9
2.	Field Output Connections for Chassis Drives	14
3.	Replacement Parts	53

Specifications

Model	Max. Armature Current (Amps DC)	HP Range with 115 VAC Applied	HP Range with 230 VAC Applied
MM311U	3.0	1/20–1/8	1/10–1/4
MM301U	10.0	1/4–1	1/2–2
MM301A	10.0	1/4–1	1/2–2

AC Line Voltage	115 VAC or 230 V AC, 50 or 60 Hz, 1 Phase
Armature Voltage (115 VAC Input)	0–90 VDC
Armature Voltage (230 VAC Input)	0–180 VDC
Form Factor	1.37 at base speed
Field Voltage (115 VAC)	50 VDC (F1 to L1); 100 VDC (F1 to F2)
Field Voltage (230 VAC)	100 VDC (F1 to L1); 200 VDC (F1 to F2)
Maximum Field Current	1 ADC
Acceleration Time Range (with no load)	1-11 seconds
Deceleration Time Range (with no load)	1-11 seconds
Analog Input Voltage Range (S1 to S2)	0-10 VDC or 4-20 mADC
Input Impedance (S1 to S2)	>100K ohms
Load Regulation (% of base speed)	
with Armature Feedback	1% or better
with Tachogenerator Feedback	0.1%
Vibration	0.5G max. (0-50 Hz); 0.1G max. (>50 Hz)

Ambient Temperature Range

Open Chassis	10°C-55°C
Cased	10°C-45°C

Weight

Open Chassis	2.1 lbs (953 grams)
Cased	7.75 lbs (3.5 kilograms)

Tachogenerator Feedback Voltage Range	7-50 VDC per 1000RPM
--	----------------------

Short-circuit current rating (SCCR) is the maximum short-circuit current that the speed control can safely withstand when protected by a specific over-current protective device(s).

The rating for models rated more than 1 HP is tabulated below:

Drive Model No.	Short Circuit Current Rating		Types of Branch Circuit Protection		Maximum Rating of Overcurrent Protection
	Maximum Current, kA	Maximum Voltage, V			
MM301U	10,000	240V	Non-time Delay K5 Fuse	Inverse Time Circuit Breaker	30A
MM301A	10,000	240V	Non-time Delay K5 Fuse	Inverse Time Circuit Breaker	30A

Dimensions

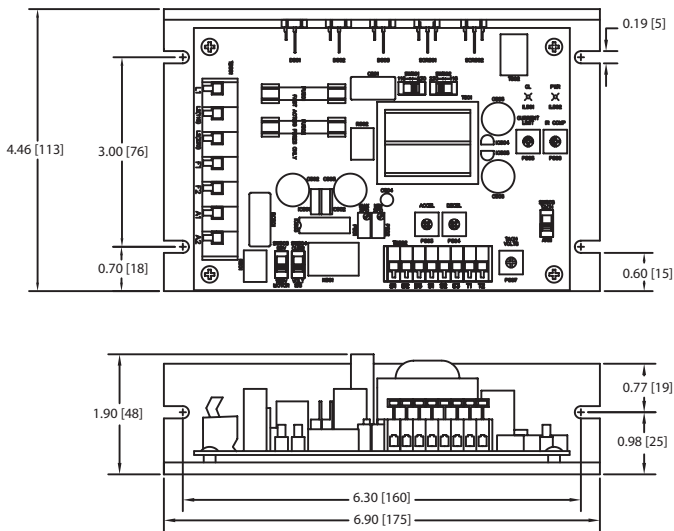

SIX (6) MOUNTING SLOTS
0.18 [5] WIDE x 0.30 [8] DEEP

ALL DIMENSIONS IN INCHES [MILLIMETERS]

Figure 1. MM301U and MM311U Dimensions

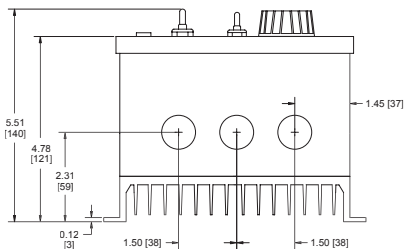
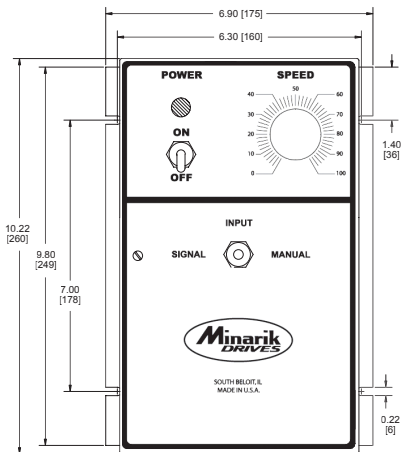

THREE 0.88 [22] KNOCKOUTS
 ALL DIMENSIONS IN INCHES [MILLIMETERS]

Figure 2. MM301A Dimensions

Installation

Wiring

Use 12 AWG wire for the AC line voltage (L1 and L2), motor armature (A1 and A2), and dynamic brake resistor (if used). Use 18 AWG wire for logic (field output, speed adjust potentiometer, tachogenerator, etc.)

Twist logic wires to avoid picking up unwanted electrical noise. Use shielded cable if wires are longer than 12 inches (30 cm).

Do not bundle logic wires with power carrying wires. This can cause erratic operation. Keep logic wires in a conduit separated by at least 2 inches from power carrying wires. Do not allow logic wires to travel in parallel to power carrying wires for more than 1 inch.

It may be necessary to earth ground the shielded cable. If noise is produced by devices other than the drive, ground the shield at the drive end. If noise is generated by a device on the drive, ground the shield at the end away from the drive. Do not ground both ends of the shield.

Shielding guidelines



Warning

Under no circumstances should power and logic leads be bundled together. Induced voltage can cause unpredictable behavior in any electronic device, including motor controls.

As a general rule, Minarik recommends shielding of all conductors. If it is not practical to shield power conductors, Minarik recommends shielding all logic-level leads. If shielding logic level leads is not practical, the user should twist all logic leads with themselves to minimize induced noise.

It may be necessary to earth ground the shielded cable. If noise is produced by devices other than the drive, ground the shield at the drive end. If noise is generated by a device on the drive, ground the shield at the end away from the drive. Do not ground both ends of the shield.

If the drive continues to pick up noise after grounding the shield, it may be necessary to add AC line filtering devices, or to mount the drive in a less noisy environment.

Logic wires from other input devices, such as motion controllers and PLL velocity controllers, must be separated from power lines in the same manner as the logic I/O on this drive.

Chassis Drives (MM301U, MM311U)

Mounting

Mount the drive with its board in either a horizontal or vertical plane. Four 0.188 inch (4.8 mm) wide slots in the chassis accept #8 pan head screws.

The chassis units do not have to be earth grounded. If you choose to ground the chassis, use a star washer beneath the head of at least one of the mounting screws to penetrate the anodized chassis surface and to reach bare metal.

Drive components are sensitive to electrostatic fields. Avoid contact with the circuit board directly. Hold the drive by the chassis only.

Protect the drive from dirt, moisture, and accidental contact. Provide sufficient room for access to the terminal block and calibration trimpots.

Mount the drive away from other heat sources. Operate the drive within the specified ambient operating temperature range.

Prevent loose connections by avoiding excessive vibration of the drive.

Observe the following guidelines when installing an isolation transformer:

- A power disconnecting device must be installed between the power line and primary of the transformer.
- If the power disconnecting device is a circuit breaker, the circuit breaker trip rating must be coordinated with the in-rush current (10-12 times full load current) of the transformer.

Heatsinking

The MM301U and MM311U contain sufficient heat sinking in its original configuration. No additional heat sinking is necessary when installed in accordance with the guidelines specified in this instruction manual. The chassis plate acts as the thermal heatsink.

Line fusing

MM300 Series drives have line fuses mounted on fuse holders 501 and 502 (FU501 and FU502). See the Replacement Parts section for preinstalled line fuse size. When replacing the line fuses, use fast acting fuses rated for 250 VAC or higher, and at least 200% of the armature current. See Figure 3 (page 5) for fuse holder location, and Table 1 for recommended line fuse sizes.

Table 1. Recommended Line Fuse Sizes

90 VDC Motor Horsepower	180 VDC Motor Horsepower	Max. DC Armature Current (amps)	AC Line Fuse Size (amps)
1/20	1/10	0.5	3
1/15	1/8	0.8	3
1/8	1/4	1.5	5
1/6	1/3	1.7	5
1/4	1/2	2.6	8
1/3	3/4	3.5	8
1/2	1	5.0	10
3/4	1 1/2	7.6	15

Minarik Drives offers a 63 mA pico fuse (part number 050-0081) which protects the transformer and logic.

Speed adjust potentiometer

Install the circular insulating disk between the mounting panel and the 10K ohm speed adjust potentiometer (see Figure 4). Mount the speed adjust potentiometer through a 0.38 inch (10 mm) hole with the hardware provided. Twist the speed adjust potentiometer wire to avoid picking up unwanted electrical noise. If potentiometer leads are longer than 18 inches (46 cm), use shielded cable.

Alternate speed adjust potentiometer connections may be found in the Application Notes section of this user guide.

Note: The user may choose to install a 5K ohm speed adjust potentiometer; however, the MIN SPD and MAX SPD trim pots must be recalibrated if the 5K ohm potentiometer is used.

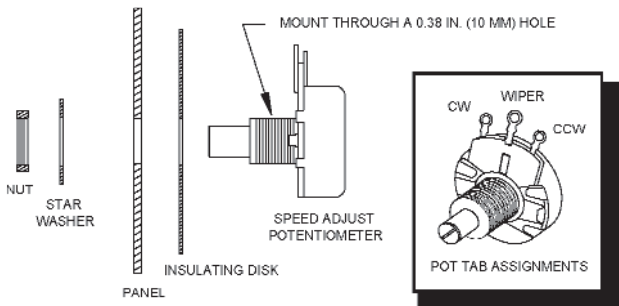

Figure 4. Speed Adjust Potentiometer

Cage-clamp terminals

Logic connections are made to a cage-clamp terminals. To insert a wire into the cage-clamp terminal:

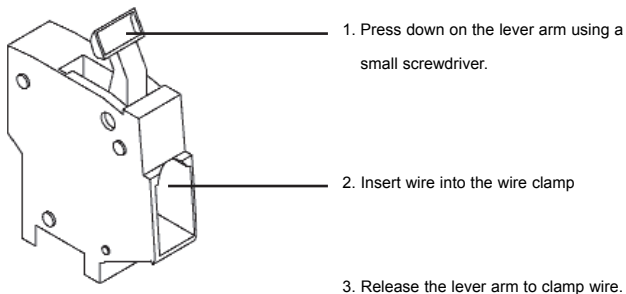

Figure 5. Cage-Clamp Terminal

Connections

Motor

**Warning**

Under no circumstances should power and logic leads be bundled together. Induced voltage can cause unpredictable behavior in any electronic device, including motor controls.

Connect a motor to terminals A1 and A2 as shown in Figure 6 (page 13). Ensure that the motor voltage rating is consistent with the drive's output voltage.

Minarik drives supply motor voltage from A1 and A2 terminals (TB501). It is assumed throughout this manual that when A1 is positive with respect to A2, the motor will rotate clockwise (CW) while looking at the output shaft protruding from the front of the motor. If this is opposite of the desired rotation, simply reverse the wiring of A1 and A2 with each other.

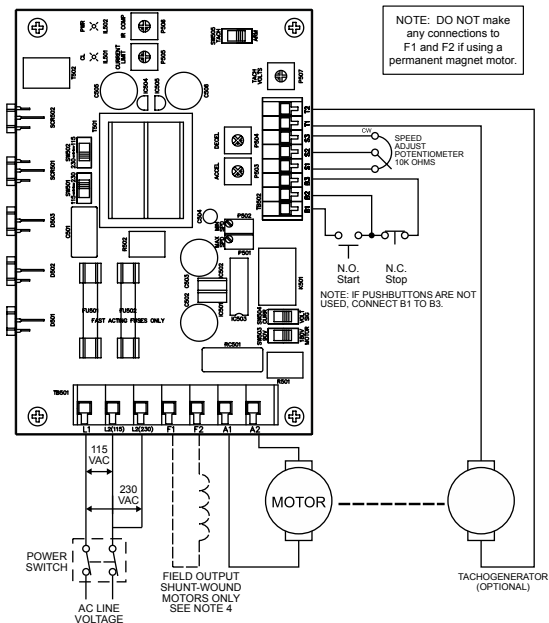

NOTES

1. L1 IS THE **HOT** TERMINAL.
2. L2/115 IS THE **NEUTRAL** TERMINAL FOR 115 VAC INPUT.
3. TYPICAL FIELD CONNECTIONS SHOWN. REFER TO TABLE 2 (PAGE 14) FOR ALTERNATE FIELD CONNECTIONS.

Figure 6. MM301U and MM311U AC Line, Motor and Field Connections

Power Input

Connect the AC line power leads to terminals L1 and L2 and install a master power switch in the voltage input line as shown in Figure 6 (page 13). The switch contacts should be rated at a minimum of 250 volts and 200% of maximum drive current.

Field output

The field output is for shunt wound motors only. **Do not make any connections to F1 and F2 (TB501) when using a permanent magnet motor.** See Table 2 for field output connections.

Table 2. Field Output Connections for Chassis Drives

Line Voltage (VAC)	Approximate Field Voltage (VDC)	Connect Motor Field To
115	50	F1 and L1
115	100	F1 and F2
230	100	F1 and L1
230	200	F1 and F2

START/STOP pushbuttons

Pushbutton operation of the MM300 Series requires a momentary normally open STOP pushbutton be wired to terminals B2 and B3 and a momentary normally closed START pushbutton wired to terminals B1 and B2. These switches must be used together and are not included with the drive. The B1, B2 and B3 terminals are on terminal block TB502.

If the START/STOP pushbuttons are not used, wire a jumper between terminals B1 and B3 to bypass the latching circuit. The drive will then operate in a power-up start mode. See Figure 6 (page 13) for these switch connections.

Tachometer feedback

Using tachometer feedback improves speed regulation from approximately 1% of motor base speed to approximately 0.1% of motor base speed. Use tachometers rated from 7 VDC per 1000 RPM to 50 VDC per 1000 RPM. Connect the tachometer to terminals T1 and T2 of terminal block 502 (TB502). Place SW504 in the TACH position. See Figure 6 (page 13) for tachometer connections. The TACH trimpot must be adjusted prior to operating with tachometer feedback. Refer to the Calibration section for instructions on calibrating the TACH trimpot.

Voltage or current follower

Instead of using a speed adjust potentiometer, MM300 Series drives may be wired to follow an analog input signal (see Figure 6 for connections). This input signal can be in the form of voltage (0-10 VDC) or current (4-20 mA). Because these drives have built in isolation the input signal can be either grounded or ungrounded. The signal slide switch must also be set for current or voltage input (see Slide switches section).

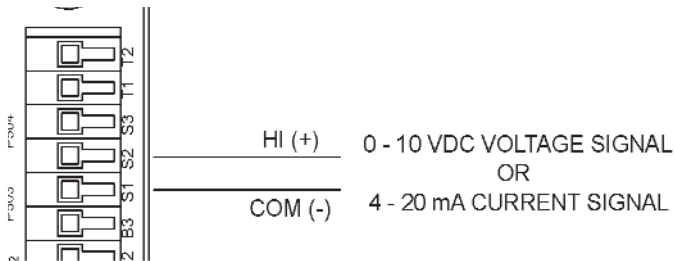

Figure 7. Signal Follower Connection

Slide switches



Warning

Change slide switch settings only when the drive is disconnected from the AC line voltage. Make sure both line voltage and motor switches are set to their correct position. If the switches are improperly set to a lower voltage position, the motor will not run at full voltage and may cause transformer damage. If the switches are improperly set to a higher voltage position, the motor will over speed, which may cause motor damage.

LINE VOLTAGE (SW501 and SW502)

Select the appropriate line voltage: 115 for 115 VAC line voltage, or 230 for 230 VAC line voltage.

MOTOR (SW503)

Select the maximum armature voltage: 90V for 90 VDC motors, or 180V for 180 VDC motors.

SIGNAL (SW504)

Select the input signal being used: CURR for current input signal, or VOLT for voltage input signal or speed adjust potentiometer input.

FEEDBACK (SW505)

Select the appropriate feedback option: ARMATURE for armature feedback, or TACH for tachometer feedback.

See Figure 8 for all slide switch locations.

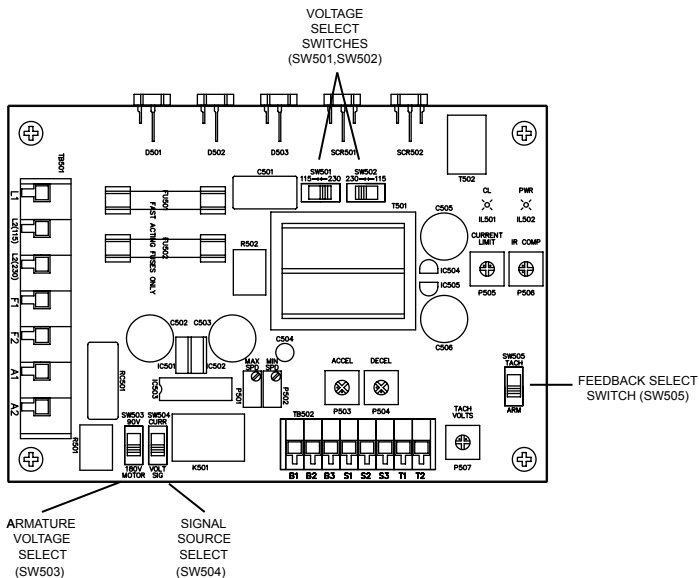

Figure 8. Slide Switches

Enclosed drive

Mounting

The NEMA 4X enclosed drive comes with 0.88 inch (22mm) conduit knockout holes at the bottom of the enclosure. The units may be vertically wall mounted using the four 0.19 inch (5 mm) slotted holes on the attached heat sink. For motor loads less than 5 ADC, the drive may be bench mounted horizontally, or operated without mounting.

Mount the drive as follows:

1. Install the mounting screws.
2. For access to the terminal strip, turn the slotted screw on the front cover counterclockwise until it is free from the enclosure. The right side of the cover is hinged to the enclosure. Pull the slotted screw to open the enclosure.
3. Carefully remove the conduit knockouts by tapping them into the enclosure and twisting them off with pliers.
4. Install conduit hardware through the 0.88 inch (22 mm) knockout holes.
Connect external wiring to the terminal block.
5. Grasp the slotted screw and tilt the front cover back into place. Avoid pinching any wires between the front cover and the enclosure.
6. Turn the slotted screw clockwise until tight to secure the front cover.
7. Set the POWER switch to the OFF position before applying AC line voltage.

Heat sinking

The enclosed MM300 Series drive contains sufficient heat sinking in its basic configuration. No additional heat sinking is necessary when installed in accordance with the guidelines specified in this manual.

Line fusing



WARNING: Most code requires that upstream branch protection be provided to protect input power wiring. Failure to observe this precaution could result in severe bodily injury or loss of life.

This MM300U Series has 15-amp line fuses preinstalled on fuse holders 501 and 502 (FU501 and FU502). When replacing the line fuses, use fast acting fuses rated for 250 VAC or higher. See Figure 3 (page 5) for fuse holder location and Table 1 (page 9) for recommended line fuse sizes.

Connections



WARNING: A single fault like a power device short may cause motor rotation when in the stop mode. The user is responsible for assuring safe conditions for operating personal by providing suitable guards, audio or visual alarms, or other devices. Failure to observe these precautions could result in bodily injury.

WARNING: To provide the motor with overload protection, local, national, and international codes (e.g., NEC/CEC) require that a motor thermostat, internal to the motor, be installed or an electronic thermal motor overload relay, sized to protect the motor, installed between the motor and the drives' output terminals.

WARNING: Do not connect this equipment with power applied. Failure to observe this precaution may result in fire or serious injury.

Connections

Motor

**Warning**

Under no circumstances should power and logic leads be bundled together. Induced voltage can cause unpredictable behavior in any electronic device, including motor controls.

Connect a motor to terminals A1 and A2 as shown in Figure 9 (page 23). Ensure that the motor voltage rating is consistent with the drive's output voltage.

Minarik Drives motor speed controls supply motor voltage from A1 and A2 terminals. It is assumed throughout this manual that when A1 is positive with respect to A2, the motor will rotate clockwise (CW) while looking at the output shaft protruding from the front of the motor. If this is opposite of the desired rotation, simply reverse the wiring of A1 and A2 with each other.

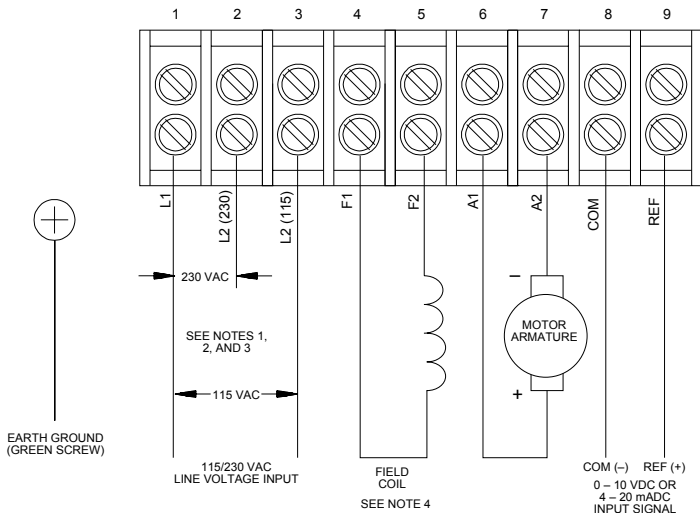

1. L1 IS THE **HOT** TERMINAL.
2. L2/115 IS THE **NEUTRAL** TERMINAL FOR 115 VAC INPUT.
3. L2/230 IS THE **NEUTRAL** TERMINAL FOR 230 VAC INPUT.
4. TYPICAL FIELD CONNECTIONS SHOWN. REFER TO TABLE 2 (PAGE 14)
5. REMOVE THE 510 OHM INTERNAL RESISTOR CONNECTED BETWEEN TERMINALS 8 & 9 IF YOU ARE USING A 0-10V REMOTE INPUT SIGNAL

Figure 9. MM301A AC Line, Motor and Field Connections

Operation

Before applying power

1. Set LINE VOLTAGE SELECT switches SW501 and SW502 to either 115V or 230V to match the AC line voltage.
2. Set ARMATURE VOLTAGE SELECT switch SW503 to either 90V or 180V to match the maximum armature voltage.
3. Set SIGNAL SELECT switch SW504 to CURR if using a 4-20 mA DC current signal; set it to VOLT if using a 0-10V DC voltage signal or the speed adjust potentiometer.
4. Verify that no conductive material is present on the printed circuit board.
5. If using a 90 VDC or 130 VDC motor with 230 VAC line voltage, derate the nameplate motor torque by at least 30%. The form factor will increase beyond the typical value, causing increased motor heating. Contact the factory for details.

Chassis Drives (MM301U, MM311U)

Speed adjust potentiometer input, no START/STOP pushbutton:

It is necessary to wire a jumper between B1 and B3 if no START/STOP switches are to be used.

1. Turn the speed adjust potentiometer full counterclockwise (CCW).

2. Apply AC line voltage.
3. Slowly advance the speed adjust potentiometer clockwise (CW). The motor slowly accelerates as the potentiometer is turned CW. Continue until the desired speed is reached.
4. Remove AC line voltage to coast the motor to a stop.

Speed adjust potentiometer input with START/STOP pushbuttons:

1. Turn the speed adjust potentiometer full counterclockwise (CCW).
2. Apply AC line voltage.
3. Press the START pushbutton.
4. Slowly advance the speed adjust potentiometer clockwise (CW). The motor accelerates as the potentiometer is turned clockwise. Continue until desired speed is reached.
5. Press STOP pushbutton to coast motor to a stop.

Analog signal input, no START/STOP pushbuttons:

It is necessary to wire a jumper between B1 and B3 if no START/STOP switches are to be used.

1. Set the analog signal so that it is at its lowest level (0V or 4mA).
2. Apply AC line voltage.
3. Slowly increase the analog signal. The motor accelerates as the signal is increased. Continue increasing signal until desired speed is reached.
4. Remove AC line voltage to coast the motor to a stop.

Analog signal input with START/STOP pushbuttons:

1. Set the analog signal so that it is at its lowest level (0V or 4mA).
2. Apply AC line voltage.
3. Press the START pushbutton.
4. Slowly increase the analog signal and press the start pushbutton. The motor accelerates as the signal is increased. Continue increasing signal until desired speed is reached.
5. Press STOP pushbutton to coast motor to a stop.

Diagnostic LEDs

MM300 Series drives are equipped with two diagnostic LEDs (see Figure 10 for LED location). The red current limit LED turns on whenever the drive reaches current limit and stays off whenever the drive is not in current limit (normal operation). The green power LED turns on whenever AC line voltage is applied to the drive and stays off whenever there is no AC line voltage applied to the drive.

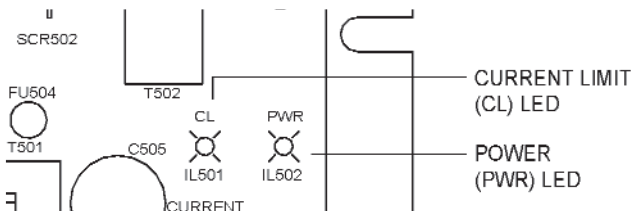

Figure 10. Current Limit and Power LEDs

Line starting and line stopping

Line starting and line stopping (applying and removing AC line voltage) is recommended for infrequent starting and stopping of a drive only. When AC line voltage is applied to the drive and a START is commanded, the motor accelerates to the speed set by the speed adjust potentiometer or analog input signal. When AC line voltage is removed, the motor coasts to a stop.

Decelerating to minimum speed

The circuit shown in Figure 11 (page 28) may be used to decelerate a motor to a minimum speed. Closing the switch between S1 and S2 decelerates the motor from set speed to a minimum speed determined by the MIN SPD trimpot setting. If the MIN SPD trimpot is set full CCW, the motor decelerates to zero speed when the switch between S1 and S2 is closed. The DECEL trimpot setting determines the rate at which the drive decelerates. By opening the switch the motor accelerates to set speed at a rate determined by the ACCEL trimpot setting.

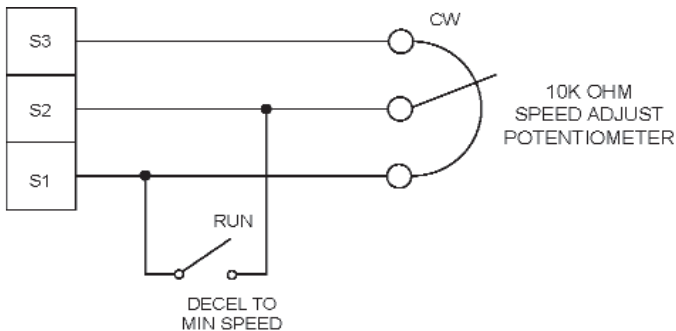

Figure 11. Run/Decelerate to Minimum Speed Switch

Dynamic Braking

Dynamic braking may be used to rapidly stop a motor (Figure 12, page 29). For the RUN/BRAKE switch, use a three pole, double throw switch rated for at least the maximum DC armature voltage, 15 amps. For the dynamic brake resistor, use a 40 Watt minimum, high power, wirewound resistor.

Dynamic Brake Resistor Value

Sizing the dynamic brake resistor depends on load inertia, motor voltage and braking time. Use a lower-value, higher wattage dynamic brake resistor to stop a motor more rapidly. A good starting point is a 40 Ohm, 40 Watt.

**Warning**

Wait for the motor to completely stop before switching it back to RUN. This will prevent high armature currents from damaging the motor.

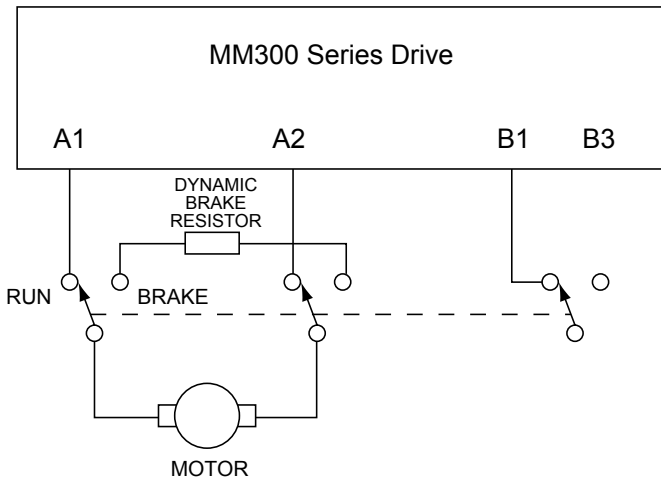

Figure 12. Dynamic Brake Connection

Enclosed drive operating modes



WARNING: If you run the drive in AUTO mode, you must recalibrate the MIN SPD trimpot to offset any motor drift caused by the input signal. Refer to the *Calibration* section (page 32) for more information.

The mode selector switch on the drive, mounted on its cover, provides the option of operating in either MANUAL (mounted speed potentiometer) or AUTO (external signal source) mode.

Manual mode

Set the mode selector switch to MANUAL if you wish to control the motor speed using the speed adjust potentiometer mounted on the drive cover. In MANUAL mode, the motor speed is controlled by the speed adjust knob located on the drive cover. Setting the speed adjust knob to zero causes the motor to run at the minimum speed dictated by the MIN SPD trimpot setting. Refer to the *Calibration* section (page 32) for information on calibrating the MIN SPD trimpot. Set SIGNAL SELECT switch SW504 to VOLT when in manual mode.

Auto mode

IMPORTANT: When switching between MANUAL and AUTO modes, you must balance the MIN SPD trimpot for both operating modes.

Set the mode selector switch to AUTO if you wish to follow an external signal, independent of the speed adjust knob setting. In AUTO mode, the drive will control motor speed in proportion to either a 0 – 10 VDC analog voltage or a 4 – 20 mA DC current signal. You must set select switch SW504 to either VOLT to follow a 0 -10 VDC analog voltage or to CURR to follow a 4 - 20 mA DC current signal.

Enclosed drive operation



WARNING: For frequent starts and stops, open the B1 and B3, decelerate to a minimum speed, or apply a dynamic brake to the motor. Do not use any of these methods for emergency stopping. They may not stop a drive that is malfunctioning. Removing AC line power (both L1 and L2) is the only acceptable method for emergency stopping.

WARNING: Frequent starting and stopping can produce high torque. This may cause damage to motors, especially gearmotors that are not properly sized for the application.

To run the motor:

1. Set the speed adjust potentiometer to "0" (full CCW).
2. Apply AC line voltage.
3. Set the POWER switch to the ON position.
4. Slowly advance the speed adjust potentiometer clockwise (CW), or increase the external reference signal. The motor will slowly accelerate to follow the speed adjust potentiometer or external reference signal. Continue until the desired speed is reached.

To stop the motor:

1. Rotate the speed adjust potentiometer to zero (full CCW), or set the external reference signal to zero. The motor will slowly decelerate until minimum speed is reached.
2. Set the POWER switch on the front panel to OFF.

Calibration



WARNING: Dangerous voltages exist on the drive when it is powered, and up to 30 seconds after power is removed and the motor stops. When possible, disconnect the voltage input from the drive before adjusting the trimpots. If the trimpots must be adjusted with power applied, use insulated tools and the appropriate personal protection equipment. BE ALERT. High voltages can cause serious or fatal injury.

WARNING: The control circuit is at line potential when the drive is energized. Exercise extreme caution as hazardous voltage exists.

MM300 Series drives have seven user adjustable trimpots. Each drive is factory calibrated to its maximum current rating. Readjust the calibration trimpot settings to accommodate lower current rated motors.

All adjustments increase with CW rotation, and decrease with CCW rotation. Use a non-metallic screwdriver for calibration. Each trimpot is identified on the printed circuit board. Refer to Figure 13 for trimpot layouts.

Drive Calibration Procedure

Prepare the MM300 series drive for calibration as follows. This procedure applies to both chassis and enclosed drives.

1. Ensure that no power is applied to the drive.
2. If you use an enclosed drive, you must open the drive cover to gain access to the trimpots. Turn the slotted screw on the front cover counterclockwise until it is free from the enclosure. The right side of the cover is hinged to the enclosure. Pull the slotted screw to open the enclosure.
3. Set all trimpots except CURRENT LIMIT and TACH VOLTS full counterclockwise (CCW).
4. Set the CURRENT LIMIT trimpot full clockwise (CW).
5. Make no adjustment to the TACH VOLTS trimpot unless tachometer feedback is used. If you use tachometer feedback, set the TACH VOLTS trimpot to the center of travel (12 o'clock position).
6. Adjust the trimpots in the following order:
 - a. MINIMUM SPEED (MIN SPD)
 - b. MAXIMUM SPEED (MAX SPD)
 - c. CURRENT LIMIT
 - d. IR COMPENSATION (IR COMP)
 - e. ACCELERATION (ACCEL)
 - f. DECELERATION (DECEL)
 - g. TACH VOLTS (if used)

MINIMUM SPEED (MIN SPD)

The MIN SPD setting determines the motor speed when the speed adjust potentiometer or input signal is set for minimum speed. It is factory set to zero speed.

To calibrate MIN SPD:

1. Turn the speed adjust potentiometer full CCW or set the input signal for minimum voltage or current.
2. Adjust the MIN SPD trimpot until the motor has stopped, or is running at the desired minimum speed.

MAXIMUM SPEED (MAX SPD)

The MAX SPD setting determines the motor speed when the speed adjust potentiometer or input signal is set for maximum speed. It is factory set for maximum rated motor speed.

To calibrate MAX SPD:

1. Set the MAX SPD trimpot full CCW.
2. Turn the speed adjust potentiometer full CW or set the input signal for maximum speed.
3. Adjust the MAX SPD trimpot until the desired maximum motor speed is reached.

Note: Check the MIN SPD and MAX SPD settings after recalibrating to verify that the motor runs at the desired minimum and maximum speeds.

CURRENT LIMIT

The CURRENT LIMIT setting determines the maximum armature current output of the drive. It is factory set at 120% of rated motor current.

To calibrate CURRENT LIMIT, refer to Figure 13 (page 33), or use the following procedure:

1. With the power disconnected from the drive, connect a DC ammeter in series with the armature.
2. Set the CURRENT LIMIT trimpot to minimum (full CCW).
3. Lock the motor armature. Be sure that the motor is firmly mounted.
4. Connect power to the drive. The motor should remain stopped.
5. Set the speed adjust potentiometer or input signal for maximum speed.
6. Adjust the CURRENT LIMIT trimpot slowly CW until the armature current is 120% of motor rated current.
7. Set the speed adjust potentiometer or input signal for zero speed.
8. Remove power from the drive.
9. Remove the stall from the motor.

IR COMPENSATION (IR COMP)

The IR COMP setting determines the degree to which motor speed is held constant as the motor load changes. It is factory set at optimum motor regulation for the highest motor horsepower.











To calibrate IR COMP, refer to Figure 13 (page 33), or use the following procedure:

1. Turn the IR COMP trimpot full CCW.
2. Set the speed adjust potentiometer or input signal until the motor runs at midspeed without load (for example, 900 RPM for an 1800 RPM motor). A hand held tachometer may be used to measure motor speed.
3. Load the motor armature to its full load armature current rating. The motor should slow down.
4. While keeping the load on the motor, rotate the IR COMP trimpot until the motor runs at the speed measured in step 2.













Approximate calibration:

If the motor does not maintain set speed as the load changes, gradually rotate the IR COMP trimpot CW. If the motor oscillates (overcompensation), the IR COMP trimpot may be set too high (CW). Turn the IR COMP trimpot CCW to stabilize the motor speed.

MM311U

CURRENT LIMIT	IR COMP	1/8 HP 90 VDC 1750 RPM 1.3 ADC	CURRENT LIMIT	IR COMP	1/4 HP 180 VDC 1750 RPM 1.4 ADC
					
CURRENT LIMIT	IR COMP	1/10 HP 90 VDC 1750 RPM 5 ADC	CURRENT LIMIT	IR COMP	1/8 HP 180 VDC 1750 RPM 0.8 ADC
					
CURRENT LIMIT	IR COMP	1/15 HP 90 VDC 1750 RPM 0.75 ADC			
					

MM301U and MM301A

CURRENT LIMIT	IR COMP	1 HP 90 VDC 1750 RPM 10 ADC	CURRENT LIMIT	IR COMP	1 HP 180 VDC 1750 RPM 5 ADC
					
CURRENT LIMIT	IR COMP	1/2 HP 90 VDC 1750 RPM 5 ADC	CURRENT LIMIT	IR COMP	1/2 HP 180 VDC 1750 RPM 2.5 ADC
					
CURRENT LIMIT	IR COMP	1/4 HP 90 VDC 1750 RPM 1.4 ADC	CURRENT LIMIT	IR COMP	1/4 HP 90 VDC 1750 RPM 1.2 ADC
					

**Figure 14. Typical CURRENT LIMIT, and IR COMP Settings for MM300 Series
(actual settings may vary with each application)**

ACCELERATION (ACCEL)

The ACCEL setting determines the time the motor takes to ramp to a higher speed, within the limits of available torque. The ACCEL setting is factory set for its fastest acceleration time (full CCW).

To calibrate ACCEL:

1. Set the speed adjust potentiometer or input signal for minimum speed. The motor should run at minimum speed.
2. Set the speed adjust potentiometer or input signal to maximum speed, and measure the time it takes the motor to go from minimum to maximum speed.
3. If the time measured in step 2 is not the desired acceleration time, turn the ACCEL trimpot CW for a slower acceleration time, or CCW for a faster acceleration time.

Repeat steps 1 through 3 until the acceleration time is correct.

DECELERATION (DECEL)

The DECEL setting determines the time the motor takes to ramp to lower speed, within the limits of available torque. The DECEL setting is factory set for its fastest deceleration time (full CCW).

To calibrate DECEL:

1. Set the speed adjust potentiometer or input signal for maximum speed. The motor should run at maximum speed.
2. Set the speed adjust potentiometer or input signal for minimum speed and measure the time it takes the motor to go from maximum to minimum speed.
3. If the time measured in step 2 is not the desired deceleration time, turn the DECEL trimpot CW for a slower deceleration time, or CCW for a faster deceleration time. Repeat steps 1 through 3 until the deceleration time is correct.

TACH VOLTS

Calibrate the TACH VOLTS setting only when a tachometer is used. The TACH VOLTS setting, like the IR COMP setting, determines the degree to which the motor speed is held constant as the motor load changes.

To calibrate the TACH VOLTS trimpot:

1. Connect the tachometer to T1 and T2. The polarity is (+) for T1 and (-) for T2 when the motor is running in forward direction.
2. Set switch SW505 to ARM for armature feedback.
3. Set the speed adjust potentiometer or input signal to maximum speed.
4. Measure the armature voltage across A1 and A2 using a voltmeter.

5. Set the speed adjust potentiometer or input signal to minimum speed.
6. Remove power from the drive.
7. Set SW505 to TACH for tachometer feedback.
8. Connect power to the drive.
9. Set the IR COMP trimpot full CCW.
10. Set the TACH VOLTS trimpot full CW.
11. Set the speed adjust potentiometer or input signal to maximum speed.
12. Adjust the TACH VOLTS trimpot until the armature voltage is the same value as the voltage measured in step 3.

Check that the TACH VOLTS trimpot is properly calibrated. The motor should run at the same set speed when SW503 is set to either armature or tachometer feedback.

Application Notes

Multiple fixed speeds

Replace the speed adjust potentiometer with series resistors with a total series resistance of 10K ohms (Figure 15). Add a single pole, multi-position switch with the correct number of positions for the desired number of fixed speeds.

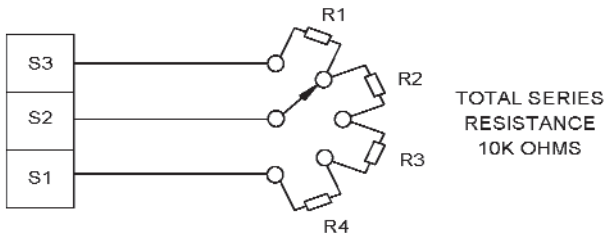

Figure 15. Multiple Fixed Speeds

Adjustable speeds using potentiometers in series

Replace the speed adjust potentiometer with a single pole, multi-position switch, and two or more potentiometers in series, with a total series resistance of 10K ohms.

Figure 16 shows a connection for fixed high and low speed adjust potentiometers.

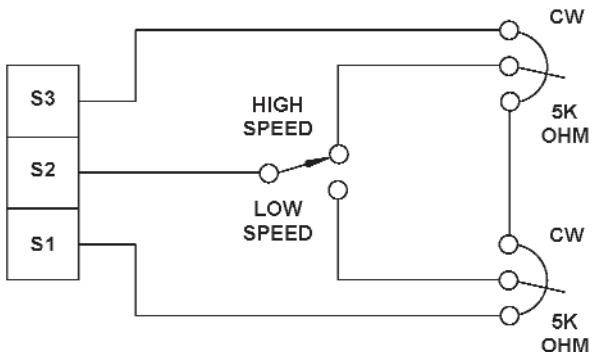

Figure 16. Adjustable Fixed Speeds Using Potentiometers in Series

Independent adjustable speeds

Replace the speed adjust potentiometer with a single pole, multi-position switch, and two or more potentiometers in parallel, with a total parallel resistance of 10K ohms.

Figure 17 shows the connection of two independent speed adjust potentiometers that can be mounted at two separate operating stations.

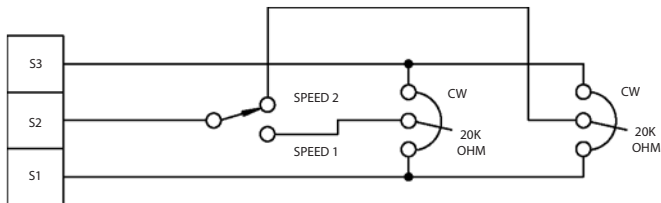

Figure 17. Independent Adjustable Speeds

RUN/JOG switch

Using a RUN/JOG switch is recommended in applications where quick stopping is not needed and frequent jogging is required. Use a single pole, two position switch for the RUN/JOG switch, and a single pole, normally closed, momentary operated pushbutton for the JOG pushbutton.

Connect the RUN/JOG switch and the JOG pushbutton as shown in Figure 19. When the RUN/JOG switch is set to JOG, the motor decelerates to minimum speed (minimum speed is determined by the MIN SPD trimpot setting). Press the JOG pushbutton to jog the motor. Return the RUN/JOG switch to RUN for normal operation.

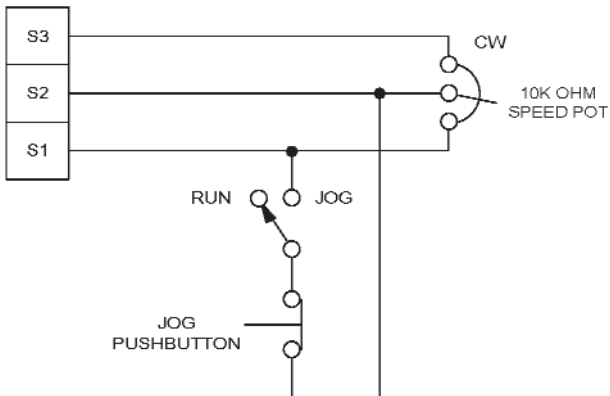

Figure 19. RUN/JOG Switch Connection to Speed Adjust Potentiometer

Reversing with a DIGI-LOK Controller (DLC600)

A DIGI-LOK controller, model DLC600 can be used in a reversing application. The DIGI-LOK must be inhibited while braking. Without the inhibit feature, the DIGI-LOK will continue to regulate. This will cause overshoot when the DIGI-LOK is switched back to the drive. Figure 20 shows the connection of the reversing circuit to a MM300 series drive and to a DLC600. **Note:** Only one DLC option (Optical Encoder or Magnetic Pickup) may be used at a time.

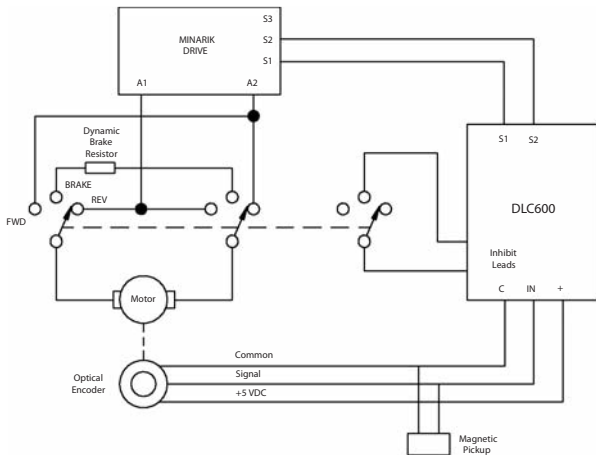

Figure 20. Reversing with a DLC600

Troubleshooting



Warning

Dangerous voltages exist on the drive when it is powered. When possible, disconnect the drive while troubleshooting. High voltages can cause serious or fatal injury.

Check the following steps before proceeding:

1. The AC line voltage must be balanced, and match the voltage on the drive name-plate.
2. On dual voltage drives, check that the slide switches are set to the correct position.
3. The motor must be rated for the drive's rated armature (all motors) and field outputs (shunt wound motors only).
4. Do not make any connections to F1 and F2 when a permanent magnet motor is used.
5. Terminal block connections should be consistent with the connections shown in this manual.
6. Check that line fuses FU501 and F502 are properly sized and not blown.

For additional assistance, contact your local Minarik distributor, or the factory direct:

PHONE: (800) MINARIK or (800) 646-2745

FAX: (800) 624-6960

Problem	Possible Causes	Suggested Solutions
Line fuse blows	<ol style="list-style-type: none">1. Line fuses are the wrong size.2. Motor cable or armature is shorted to ground.3. Nuisance tripping caused by a combination of ambient conditions and high-current spikes (i.e. reversing).4. Field circuit is open.	<ol style="list-style-type: none">1. Check that line fuses are correct for motor size (page 9).2. Check motor cable and armature for shorts.3. Add a blower to cool the drive components, or decrease the duty cycle of the system.4. Send drive to Minarik repair department.
Motor runs too fast at maximum speed setting	<ol style="list-style-type: none">1. MIN SPD and MAX SPD settings are too high.2. Motor field connections are loose (shunt wound motors only).3. Motor is demagnetized.4. Tachometer leads are reversed.	<ol style="list-style-type: none">1. Recalibrate MIN SPD and MAX SPD.2. Check motor field connections.3. Check for proper braking technique and method by which power is cycled.4. Check tachometer connections.

Problem	Possible Causes	Suggested Solutions
Line fuse does not blow, but the motor does not run	<ol style="list-style-type: none"><li data-bbox="350 219 627 286">1. Speed adjust pot, voltage input signal, or current input signal set to zero speed.<li data-bbox="350 337 627 451">2. Speed adjust pot, voltage input signal, or current input signal not connected to drive input properly; connections are open.<li data-bbox="350 505 550 524">3. S2 is shorted to S1.<li data-bbox="350 577 578 595">4. Drive is in current limit.<li data-bbox="350 744 596 788">5. Drive is not receiving AC line voltage.<li data-bbox="350 841 583 860">6. Motor is not connected.<li data-bbox="350 937 627 1002">7. B1 not connected to B3 (if START/STOP push-buttons are not used).	<ol style="list-style-type: none"><li data-bbox="653 219 923 286">1. Increase the speed adjust pot, voltage, or current setting.<li data-bbox="653 341 923 408">2. Check connections to input. Verify that connections are not open.<li data-bbox="653 509 806 527">3. Remove short.<li data-bbox="653 580 907 672">4. Verify that motor is not jammed. Increase CURRENT LIMIT setting if it is set too low.<li data-bbox="653 750 917 792">5. Apply AC line voltage to L1 and L2.<li data-bbox="653 845 902 887">6. Connect motor to A1 and A2.<li data-bbox="653 939 847 958">7. Connect B1 to B3.

Problem	Possible Causes	Suggested Solutions
Line fuse blows	<ol style="list-style-type: none">1. Line fuses are the wrong size.2. Motor cable or armature is shorted to ground.3. Nuisance tripping caused by a combination of ambient conditions and high-current spikes (i.e. reversing).4. Field circuit is open.	<ol style="list-style-type: none">1. Check that line fuses are correct for motor size (page 9).2. Check motor cable and armature for shorts.3. Add a blower to cool the drive components, or decrease the duty cycle of the system.4. Send drive to Minarik repair department.
Motor runs too fast at maximum speed setting	<ol style="list-style-type: none">1. MIN SPD and MAX SPD settings are too high.2. Motor field connections are loose (shunt wound motors only).3. Motor is demagnetized.4. Tachometer leads are reversed.	<ol style="list-style-type: none">1. Recalibrate MIN SPD and MAX SPD.2. Check motor field connections.3. Check for proper braking technique and method by which power is cycled.4. Check tachometer connections.

Block Diagram

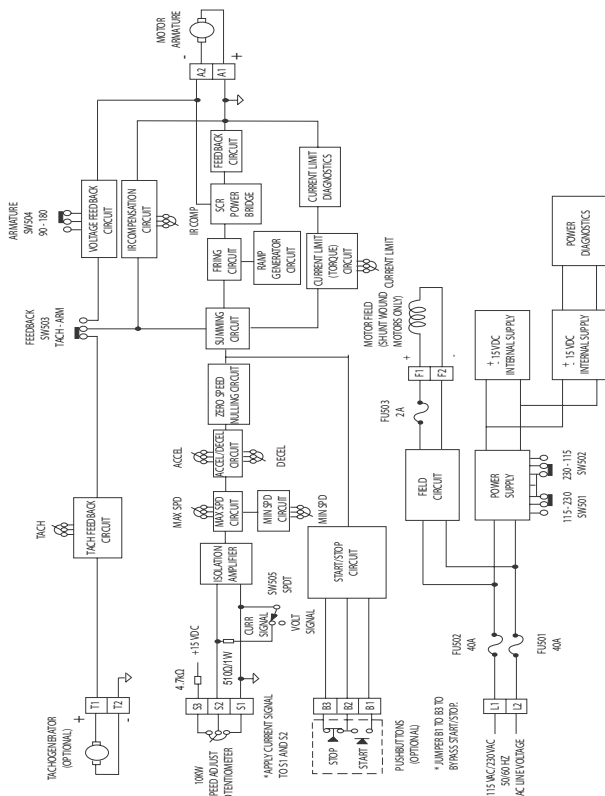

Figure 21. MM300 Series Block Diagram

Replacement Parts

Replacement parts are available from Minarik Corporation and its distributors for this drive series.

Table 3. Replacement Parts

Model No.	Symbol	Description	Minarik P/N
MM301U	D501,502, 503	20 A, 800 V Diode, D8020L	071-0039
	IC503	IS0122P IC	060-0106
	R501	.01 Ohm, 5 W Resistor	032-0129
	SCR501-502	800 V, 20 SCR, S8020L	072-0043
	T501	DST-436 Transformer	230-0072
	FU501, 502	15 A Fuse, Normal Blow	050-0018
		Heat Sink	223-0252
		10K Ohm Potentiometer Kit	202-0003
		63mA Pico fuse	050-0081
MM311U	Same as MM301U except:		
	R501	0.1 Ohm, 5 W Resistor	032-0100
	FU501, 502	5 A, Fast Acting Fuse	050-0022
MM301A	Same as MM301U except:		
	Knob		140-0013
	240V Pilot Light		040-0043
	DPST Power / Signal-Manual Switch		080-0037
	Power / Signal-Manual Boot		155-0078
Potentiometer	10 kOhm, 5 W, 5% Tolerance	120-0009	

Unconditional Warranty

A. Warranty - Minarik Drives warrants that its products will be free from defects in workmanship and material for twelve (12) months or 3,000 hours, whichever comes first, from date of manufacture thereof. Within this warranty period, Minarik Drives will repair or replace, at its sole discretion, such products that are returned to Minarik Drives, 14300 De La Tour Drive, South Beloit, IL 61080 USA.

This warranty applies only to standard catalog products, and does not apply to specials. Any returns for special controls will be evaluated on a case-by-case basis. Minarik Drives is not responsible for removal, installation, or any other incidental expenses incurred in shipping the products to and from the repair point.

B. Disclaimer - The provisions of Paragraph A are Minarik Drives's sole obligation and exclude all other warranties of merchantability for use, express or implied. Minarik Drives further disclaims any responsibility whatsoever to the customer or to any other person for injury to the person or damage or loss of property of value caused by any product that has been subject to misuse, negligence, or accident, or misapplied or modified by unauthorized persons or improperly installed.

C. Limitations of Liability - In the event of any claim or breach of any of Minarik Drives's obligations, whether express or implied, and particularly of any other claim or breach of warranty contained in Paragraph A, or of any other warranties, express or implied, or claim of liability that might, despite Paragraph B, be decided against Minarik Drives by lawful authority, Minarik Drives shall under no circumstances be liable for any consequential damages, losses, or expense arising in connection with the use of, or inability to use, Minarik Drives product for any purpose whatsoever.

An adjustment made under warranty does not void the warranty, nor does it imply an extension of the original 12-month warranty period. Products serviced and/or parts replaced on a no-charge basis during the warranty period carry the unexpired portion of the original warranty only.

If for any reason any of the foregoing provisions shall be ineffective, Minarik Drives's liability for damages arising out of its manufacture or sale of equipment, or use thereof, whether such liability is based on warranty, contract, negligence, strict liability in tort, or otherwise, shall not in any event exceed the full purchase price of such equipment.

Any action against Minarik Drives based upon any liability or obligation arising hereunder or under any law applicable to the sale of equipment or the use thereof, must be commenced within one year after the cause of such action arises.

Notes



MINARIK DRIVES
www.minarikdrives.com

14300 De La Tour Drive, South Beloit, IL 61080

Phone: (800) 646-2745

Fax: (800) 624-6960

Document number 250-0175, Revision 10

Printed in the U.S.A - July 2013